

Regain the freedom of your home



The Acorn 130 Superglide Straight Stairlift

The Acorn Superglide Stairlift is one of the most technologically advanced stairlifts available, helping thousands of people worldwide to reclaim full access to their home. It's the safe, comfortable and simple solution to difficulty with the stairs.

Every aspect of the Acorn Superglide has been designed for the highest standards of comfort and safety. Our years of experience have helped us to create a stairlift that is built purely with the user in mind.

The Acorn Superglide is powered by a maintenance free DC power pack, which ensures your lift works even in the event of a power cut.

The Superglide's smooth start/stop action means just that, no sudden jerks or jolts; and the near silent motion of the lift blends unobtrusively into your home.

Another feature pioneered by Acorn is the on-board diagnostic control panel which alerts you to any potential problems before they arise, (e.g. the stairlift has accidentally been switched off or incorrectly parked).

You can rest safe in the knowledge that tens of thousands of homes worldwide have already enjoyed the Acorn experience.



Give your life a lift[®]

Enjoy the home you love

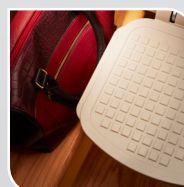

A wealth of features for your benefit



- 1 Padded seat and backrest.
- 2 Easy to use controls.
- 3 Secure safety belt.
- 4 Folding arms, footrest and seat allow easy access to the stairway.
- 5 Swivel seat - no need for twisting the body to get on and off the lift.
- 6 Lockable on/off switch allows the user to prevent others (e.g. children) from using the lift.
- 7 Diagnostic digital display informs the user of the status of the lift.
- 8 Five safety sensors on the footrest and carriage stop the lift automatically if any obstruction is encountered.
- 9 Hand-held remote controls allow users to 'call' or 'send' the lift up and down the staircase.

Dimensions

	mm	inch
A Floor to top of footrest	95	3¾
B Top of footrest to top of seat	445	17½
C Top of seat to top of arms	250	9¾
D Top of arms to top of seat back	190	7½
E Width between armrests (Wide arm version)	445 (495)	17½ (19½)
F Overall width	605	23¾
G Overall height	980	38½
H Length of arms from seat back	470	18½
I Length of seat base from seat back	435	17
J Length of footrest	325	12¾
K Width of footrest	310	12¼
L Front of footrest to stringer	570	22½
M Back of seat to stringer	13	½
N Folded width	310	12¼

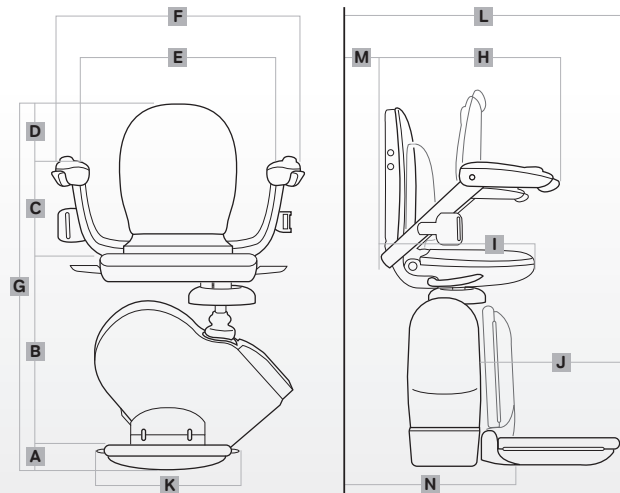

Specifications

Motor Power	0.25KW
Motor Output Speed	No greater than 0.15 m/s
Method of Drive	Rack and Pinion
Motor Output Torque	108Nm

Power Supply	24V DC (battery)
Maximum Capacity	127kgs
Track	Extruded Aluminium
Mains Supply	UK 240V / EC 220V - 50Hz Charger

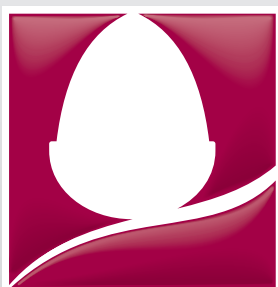

ACORN
STAIRLIFTS

Dealer Stamp

Acorn Mobility Services Ltd · Telecom House
Millennium Business Park · Station Road · Steeton · West Yorkshire · BD20 6RB

Acorn reserves the right to change specifications without notice. All measurements are approximate. Images are shown for illustrative purposes only. Product may vary slightly.