

# Levant

## The Ergonomic & Esthetic Stairlift

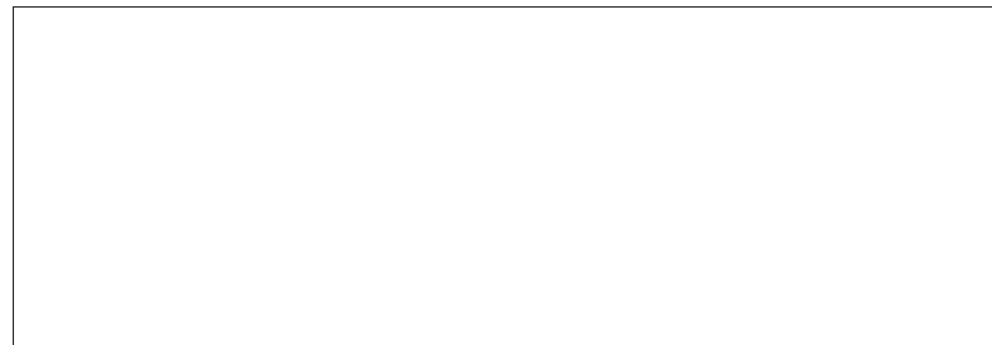

**ThyssenKrupp Accessibility BV**  
Van Utrechtweg 99, P.O. Box 754  
2920 CB Krimpen aan den IJssel  
The Netherlands  
Phone: +31 (0)180 530988  
Fax: +31 (0)180 530998  
E-mail: [info@tka-international.com](mailto:info@tka-international.com)  
[www.tka-international.com](http://www.tka-international.com)

All statements as to the properties or utilization of the materials and products mentioned in this brochure are for the purpose of description only. Guarantees in respect of the existence of certain properties or utilization of the material mentioned valid are only if agreed upon in writing. Subject to technical changes without notice. Reprints, even extracts, only with permission of the publisher.

A ThyssenKrupp  
Elevator company

**ThyssenKrupp Access**



**ThyssenKrupp**



### Levant

The Levant is an attractive and discrete addition to your home, elegantly blending in to your home and always ready to use. It helps you to move between all levels of your home with maximum comfort and safety.

### Ergonomics, design and functionality in one

Working closely with ergo-therapists and international focus groups, Levant is the next generation stairlift. By consulting ergonomics experts as well as existing stairlift owners the Levant design is simple, sturdy and above all matches your accessibility requirements.

Levant's simplicity allows the stairlift to be installed in your home very quickly. Fitted directly onto your stairs cleanly and discretely, the stairlift glides swiftly along an aluminium track. Following installation, a qualified engineer will provide you with a comprehensive demonstration

to allow you to become quickly acquainted with Levant's easy to operate controls. After that, your Levant is completely ready to use.

### Safety & Comfort

Quality, service and reliability are fundamental to our stairlift design. Levant adheres to the latest stringent international safety certification, you can be assured of the highest service and quality levels. Pressure sensitive edging around the stairlift provides extra security in the event of an obstruction on your stairs and the footrest protects against any trapping hazard.

An On/Off switch is fitted as standard, this keeps the batteries charged if you were to go on holiday and unplug the Levant. With normal use the batteries have a long usage cycle. For instance when the rail is 5 meters and has angle of 45 degrees, the stairlift can make 25 rides.



### Seat

The ergonomically designed seat makes the ride smooth and comfortable. Generous seat adds to the comfort. When folded up the seat takes up significantly less space, so the stairs are free for other users.



### Rail

The lightweight aluminium rail gives the Levant a modern look. In addition the aluminium rail is anodised; this keeps the surface clean. The rail supports are powder coated on RAL 7046, that colour fits neatly with aluminium. All the plastic parts on the rail are black (RAL 9011). This way the cable for charging contacts goes almost unnoticed in the rail.



### Call & Send

The slim design handsets can be positioned at the top and bottom of your stairs to allow you to call your Levant at any time. This makes it easy also for additional members of your household to use the stairlift. The hold-to-run buttons ensure maximum safety with usage.



### Swivel seat

The swivel seat ensures that your stairlift turns safely away from the stairs. The handle is easy to operate and can be used on both sides of the chair. This way you can choose what is most convenient for your situation.



### Control Unit

Levant is operated with an easy to use joystick. Simply move the joystick left or right depending on whatever you would like to go up or down your staircase.



### Seat belt

A seat belt gives you a maximum security. The seat belt is an easy-to-use click system.

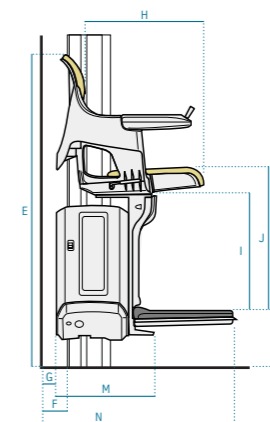
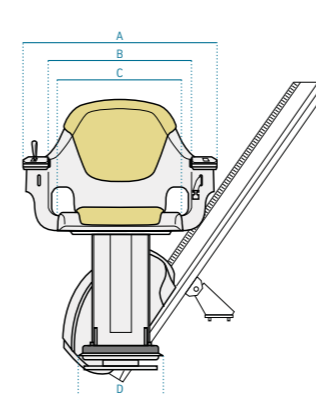

## Technical specifications

Lifting capacity	: 127 - 138 Kg
Operation	: Flow2 control unit, joystick operation (also functions as key). Infra red call and send station with push button.
Drive system	: Battery (24VDC), rack and pinion drive system.
Rail	: Anodised aluminium.
Inclination	: 28° up to 53°
Speed	: max. 0.1 m/s
Technical conformity	: EN81-40 & EN55022 for CE and ASME18.1 approved.
Standard specification	: 5 meter basic rail with basic chair.
Main options	: Upholstery and call and send stations.

## Spaceclaim

dimensions in millimeter	
A Total width	655
B	485
C Folding seat width	422
D	295
E	963 (848 + K)
F	74
G When not swivelled	34
H Seat depth	410
I	400
J	478 (450 without upholstery)
K	115 (94 - 118)
L	368
M	598
N	632 (M + G)